



On-Board Diagnostics Symposium–Europe

sae.org/obd-eu

March 14-16, 2023 | Prague, Czech Republic



On-Board Diagnostics Symposium–Europe

sae.org/obd-eu



March 14-16, 2023
Prague, Czech Republic

CARB Mandated OBD Compliance Reporting Update

HRCS OBD signal flow analysis working
group

Matthias Hampel



concentrio

HRCS working group on OBD signal flow analysis

Kickoff: October 18, 2022

Chairman: John Van Gilder

Secretary: Matthias Hampel



VAN GILDER ENGINEERING



Scope of the working group

There are several use cases related to automotive emissions compliance, safety analysis, system validation, fault isolation and event analysis that require an understanding of the propagation of signals within and between the vehicle's Electronic Control Units (ECUs)

Specifically:

CARB request to all OEMs in 2019 ...

(1) Certification Documentation

(2) The following information shall be submitted as “Part 1” of the certification application. ... The information must include: ...

(2.8) A listing of **all electronic powertrain input and output signals** (including those not monitored by the OBD II system) that identifies which signals are monitored by the OBD II system

The focus of the working group is to develop methods to meet these requirements and to specify standards for portions of the process required for cost effective implementation for all stakeholders.

Approach for tool based signal flow analysis

Best practice following the steps: Create / Exchange / Analyze

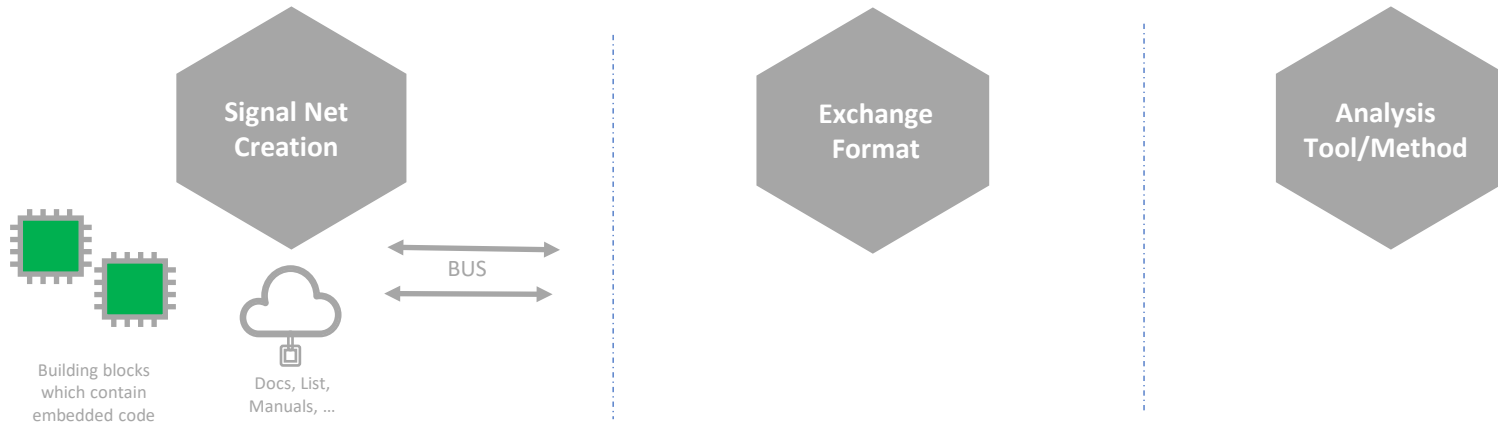

Partly automated generation of signal net artifacts based on source code from each ECU.

Individual exchange format.
Enable suppliers to deliver their own inputs.

Analysis Tool/Method

- Import / merge
- Queries
- Export

Agenda

- Definition of CARB OBD-relevant
- Scope of disclosure
- Disclosure format
- Sample data
- Test cases for use case verification
- Outlook & next steps

Definition of CARB OBD-relevant

HRCS proposes that “electronic powertrain input and output signals” means all inputs to, and outputs from a DEC ECU that are “**CARB OBD-relevant**”.

A “**CARB OBD-relevant**” signal is any signal that influences the control or diagnosis of any emissions-related component or system (i.e., subject to CARB OBD II or HD OBD monitoring requirements), including emissions-neutral diagnostics, emissions-neutral default actions, safety-only (aka "safety-exempt") components/systems, and any other components or systems with failures that can adversely impact emissions but are exempt from monitoring (e.g., components/systems 'tested out' in accordance with 13CCR1968.2(e)/(f)(15.1.2), components/systems not subject to monitoring due to low temperature exemption of 13CCR1968.2(e)(17.8)/(f)(17.7), components/systems not subject to monitoring due to high vehicle speed exemption of 1968.2(e)(17.9)/(f)(17.8)).

Scope of disclosure – proposed to CARB

The proposed scope of disclosure for serial I/O is targeted at providing the information that is of interest to CARB while also seeking to keep the volume of generated/documented/submitted data to a manageable minimum.

CARB's stated objectives for the serial data signal disclosure (from HRCS/CARB meeting):

- Determine if manufacturers have 'done their homework' in identifying all emissions-related OBD dependencies
- Understand what content is on the vehicle and which components are relevant from OBD II or HD OBD perspective
- Use as a reference when reviewing contents of the diagnostic checklist (cert doc Section B)

Scope of disclosure – proposed to CARB (cont'd)

The minimum requirement is for manufacturers to disclose all CARB OBD-relevant serial data signals at the point where they cross a DEC ECU/non-DEC ECU boundary:

- Serial data transmitted between DEC ECUs can be excluded based on the premise that such signals or their fundamental constituents would be documented at the point where they first cross the DEC ECU/non-DEC ECU boundary as either a hard-wired input to, or output from a DEC ECU, or serial data received from, or transmitted to a non-DEC ECU or smart device.
- Manufacturers can choose to document and submit more than the minimum required information if it is more convenient for their analysis/documentation toolchain

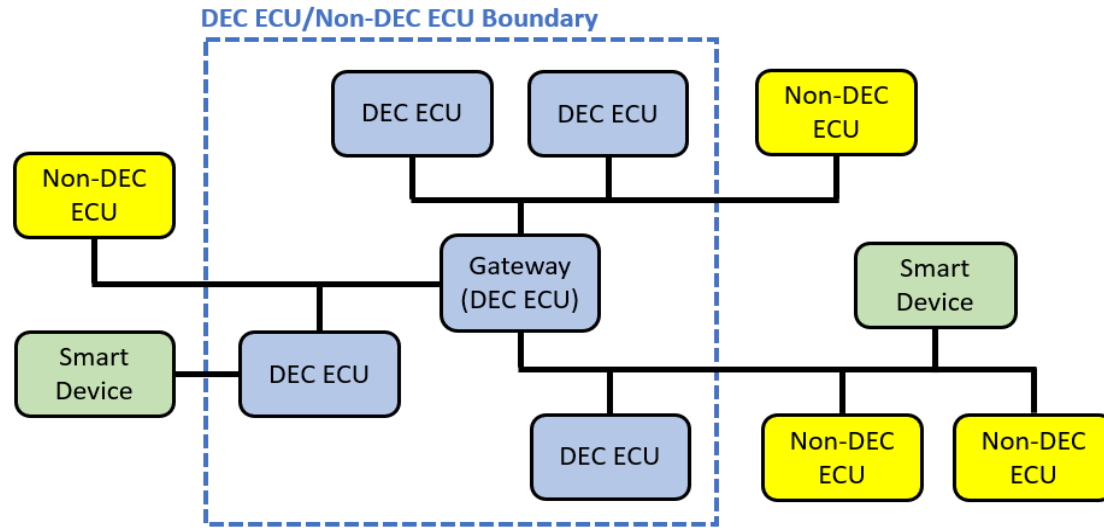

Scope of disclosure – proposed to CARB (cont'd)

- Serial data 'infrastructure' (aka 'non-payload') signals, such as MAC (message authentication code), ARC (alive rolling count), PV (protection value), and checksum are excluded.
- To reduce analysis complexity and time, manufacturers have the option to submit a 'superset' signal list, meaning a signal list that covers all or multiple applications for a given model year rather than providing unique lists for each OBD group/application.
- Gateways (and other ECUs that gate signals) can be 'ignored' (i.e., considered neither transmitters nor receivers of signals) for serial data that it gates unless the gating ECU uses the signal for a CARB OBD-relevant purpose and is the point where the signal crosses the DEC ECU/non-DEC ECU boundary.
- In practical terms, the proposed ruleset will result in documenting the following:
 - Serial data signals that are received by a DEC ECU from a Non-DEC ECU that are: (1) safety-exempt, (2) part of an emissions-neutral diagnostic strategy, or (3) covered by some other CARB OBD monitoring exception
 - Serial data signals that are transmitted by a DEC ECU to a smart device that are used for an emissions-related control or diagnostic purpose
 - Serial data signals transmitted by a smart device to a DEC ECU that are used for an emissions-related control or diagnostic purpose

Disclosure format – proposed to CARB

Manufacturers have the option to provide a serial data signal list on a per-ECU basis (e.g., as an addendum to the pin-out signal list for each ECU) or as a single list that encompasses all ECUs. Examples of a proposed format for each option is provided below:

Serial Data Input/Output Signal List for <ECU Name>

Signal Name	Transmitting ECU	Serial Bus	OBD Classification
<emissions-related signal>	<Source ECU name>	<serial bus name>	Emissions-Related MIL
<emissions-neutral signal>	<Source ECU name>	<serial bus name>	Non-MIL/Not Monitored
<safety emissions-neutral signal>	<Source ECU name>	<serial bus name>	Non-MIL/Not Monitored
<safety-exempt signal>	<Source ECU name>	<serial bus name>	Non-MIL/Not Monitored
<not monitored signal>	<Source ECU name>	<serial bus name>	Non-MIL/Not Monitored
<not CARB OBD-relevant signal>	<Source ECU name>	<serial bus name>	Not CARB OBD-Relevant

Table 1: Proposed format for disclosure of CARB OBD-Relevant serial data input and output signals if documented on a per-ECU basis.

Disclosure format – proposed to CARB (cont'd)

Serial Data Input/Output Signal List

Signal Name	Receiving ECU	Transmitting ECU	Serial Bus	OBD Classification
<emissions-related signal>	<Receiving ECU name>	<Source ECU name>	<serial bus name>	Emissions-Related MIL
<emissions-neutral signal>	<Receiving ECU name>	<Source ECU name>	<serial bus name>	Non-MIL/Not Monitored
<safety emissions-neutral signal>	<Receiving ECU name>	<Source ECU name>	<serial bus name>	Non-MIL/Not Monitored
<safety-exempt signal>	<Receiving ECU name>	<Source ECU name>	<serial bus name>	Non-MIL/Not Monitored
<not monitored signal>	<Receiving ECU name>	<Source ECU name>	<serial bus name>	Non-MIL/Not Monitored
<not CARB OBD-relevant signal>	<Receiving ECU name>	<Source ECU name>	<serial bus name>	Not CARB OBD-Relevant

Table 2: Proposed format for disclosure of CARB OBD-relevant serial data input and output signals if documented in a single table:

Disclosure format – feedback from CARB

- Request to ensure that the naming of the signals and busses is sufficiently descriptive
- Is it possible to categorize/group the signal names by function groups or add a short description about the purpose of the signal?
- Would it be possible to show the association between signal names and DTCs e.g. in another column?
- Remark: Not CARB OBD-relevant signals need to be disclosed as well
- Request to provide some sample data of how a disclosure in the proposed format looks like
- Request to make the process of creating the IO disclosure list transparent

Disclosure format – proposed to CARB (cont'd)

For both table options, the “OBD Classification” column is populated with one of the following:

- **Emissions-Related MIL:** indicates that the signal is covered by MIL-illuminating monitor(s); should be documented in cert doc Section B (Checklist) and cert doc Section C (Summary Table)
- **Non-MIL/Not Monitored:** indicates that the signal is covered by EO-approved non-MIL-illuminating monitor(s) executed in either a DEC ECU or non-DEC ECU (i.e., emissions-neutral diagnostic/default action strategy) or an EO-approved monitoring exemption (e.g., components/systems 'tested out' in accordance with 13CCR1968.2(e)/(f)(15.1.2), components/systems not subject to monitoring due to low temperature exemption of 13CCR1968.2(e)(17.8)/(f)(17.7), components/systems not subject to monitoring due to high vehicle speed exemption of 1968.2(e)(17.9)/(f)(17.8)); should be documented in cert doc Section N (Non-MIL/Non-OBD Components)
- **Not CARB OBD-Relevant:** indicates that the signal is not relevant from a legislated OBD perspective; not monitored; not listed in cert doc; shouldn't be any of these in signal list if manufacturer chooses to submit only the minimum required data; can be used to indicate irrelevant signals for manufacturers that submit more than the minimum required signal list.

Sample data – OEM1

Serial Data Input/Output Signal List

Signal Name	Receiving ECU	Transmitting ECU	Serial Bus	OBD Classification
Chime Manager Status	Body Control Module "A"	Instrument Panel Cluster Control Module	Bus "F"	Not CARB OBD-Relevant
Propulsion Cooling Fan 1 External Motor Open Circuit	Engine Control Module	Fan 1	ECM_LIN1	Emissions-Related MIL
Propulsion Cooling Fan 1 External Motor Short To Ground	Engine Control Module	Fan 1	ECM_LIN1	Emissions-Related MIL
Propulsion Cooling Fan 1 External Motor Short To Power	Engine Control Module	Fan 1	ECM_LIN1	Emissions-Related MIL
Propulsion Cooling Fan 1 Speed Actual	Engine Control Module	Fan 1	ECM_LIN1	Emissions-Related MIL
Fuel Tank Primary Fuel Level Sensor : Sensor Raw Value	Engine Control Module	Fuel Pump Control Module	Bus "D"	Emissions-Related MIL
Fuel Tank Zone Module Brushed Fuel Pump Sensed Duty Cycle	Engine Control Module	Fuel Pump Control Module	Bus "D"	Emissions-Related MIL
Fuel Tank Zone Module Brushless Fuel Pump Sensed Speed	Engine Control Module	Fuel Pump Control Module	Bus "D"	Emissions-Related MIL
Fuel Tank Zone Module Fuel Pump : Ground Short Circuit Status	Engine Control Module	Fuel Pump Control Module	Bus "D"	Emissions-Related MIL
Fuel Tank Zone Module Fuel Pump : Open Circuit Status	Engine Control Module	Fuel Pump Control Module	Bus "D"	Emissions-Related MIL
Fuel Tank Zone Module Fuel Pump : Phase to Phase Short Circuit Status	Engine Control Module	Fuel Pump Control Module	Bus "D"	Emissions-Related MIL
Fuel Tank Zone Module Fuel Pump : Power Short Circuit Status	Engine Control Module	Fuel Pump Control Module	Bus "D"	Emissions-Related MIL
Sensed Fuel Tank Vapor Gauge Pressure Sensor Percent of Reference Voltage	Engine Control Module	Fuel Pump Control Module	Bus "D"	Emissions-Related MIL
Serial Data 35 Protected : Adaptive Cruise Control Active Authenticated	Engine Control Module	Image Processing Module "A"	Bus "A"	Non-MIL/Not Monitored
Serial Data 35 Protected : Adaptive Cruise Control Braking Request Active Authenticated	Engine Control Module	Image Processing Module "A"	Bus "A"	Non-MIL/Not Monitored
Steering Wheel Information Protected : Steering Wheel Angle Authenticated	Engine Control Module	Power Steering Control Module "A"	Bus "A"	Non-MIL/Not Monitored
Steering Wheel Information Protected : Steering Wheel Angle Authenticated Don't Use Data	Engine Control Module	Power Steering Control Module "A"	Bus "A"	Non-MIL/Not Monitored
Occupant Restraint Information Protected : Driver Seat Belt Status Authenticated	Engine Control Module	Restraints Control Module	Bus "A"	Non-MIL/Not Monitored
Occupant Restraint Information Protected : Driver Seat Belt Status Authenticated Invalid	Engine Control Module	Restraints Control Module	Bus "A"	Non-MIL/Not Monitored
Automatic Leveling Control General Information : Vehicle Top Speed Limit Request Type	Engine Control Module	Suspension Control Module "A"	Bus "A"	Non-MIL/Not Monitored
Automatic Leveling Control General Information : Vehicle Top Speed Limit Request Value	Engine Control Module	Suspension Control Module "A"	Bus "A"	Non-MIL/Not Monitored
Propulsion Cooling Fan 1 Speed Command	Fan 1	Engine Control Module	ECM_LIN1	Emissions-Related MIL
Fuel Tank Zone Module Brushed Fuel Pump Duty Cycle Command	Fuel Pump Control Module	Engine Control Module	Bus "D"	Emissions-Related MIL
Fuel Tank Zone Module Brushless Fuel Pump Speed Command	Fuel Pump Control Module	Engine Control Module	Bus "D"	Emissions-Related MIL
Serial Data 47 Protected : Lateral Acceleration Raw Authenticated	Transmission Control Module	Restraints Control Module	Bus "A"	Non-MIL/Not Monitored
Serial Data 47 Protected : Longitudinal Acceleration Raw Authenticated	Transmission Control Module	Restraints Control Module	Bus "A"	Non-MIL/Not Monitored

Sample data – OEM2

Application for certification OBD II Input Output list BUS OBDG X Vehicle X MY XXXX ECM XXX				
				ISSUED June 30, XXX
input				
BUS	short name	long name	OBD relevant	
CAN_01_XX	ACLNX_XXXXXXX	longitudinal-acXXXXXX		no
CAN_02_XX	ActualValueXXXXXX	ActualValueXXXXXX		no
CAN_01_XX	AVL_XXXXX	actual-value_XXXXX		no
LIN_01_X	COMM_ERR_XXXXXX	communication_error_XXXXXXX		no
CAN_01_XX	ST_EOLXXXX	status_end-of-XXXXXX		no
CAN_02_XX	AVL_RPM_XXXX	actual-value_RPM_XXXX	yes	
CAN_02_XX	TAR_RPM_XXX	target_RPM_XXX	yes	
End				

Test cases for use case verification

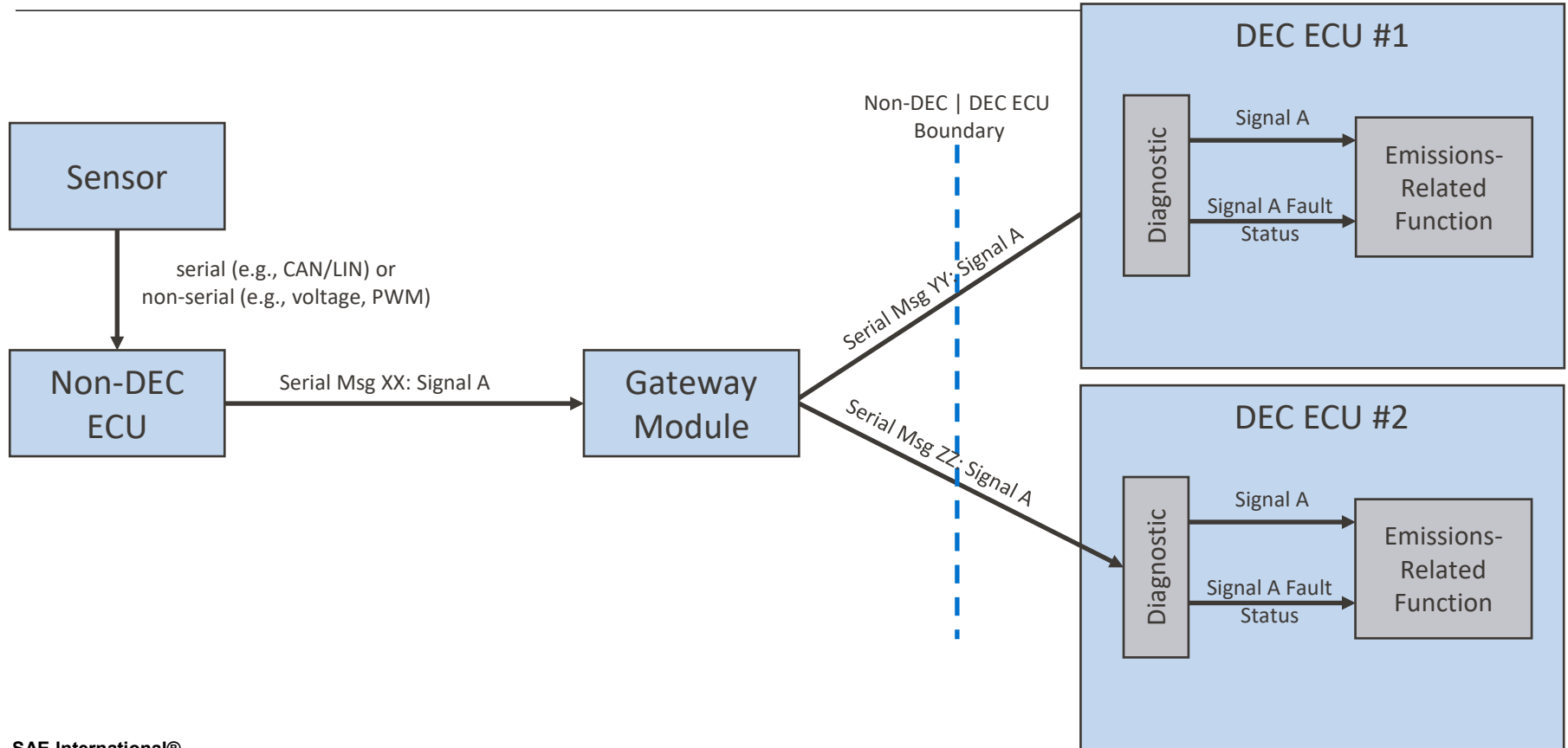

Test cases for use case verification (cont'd)

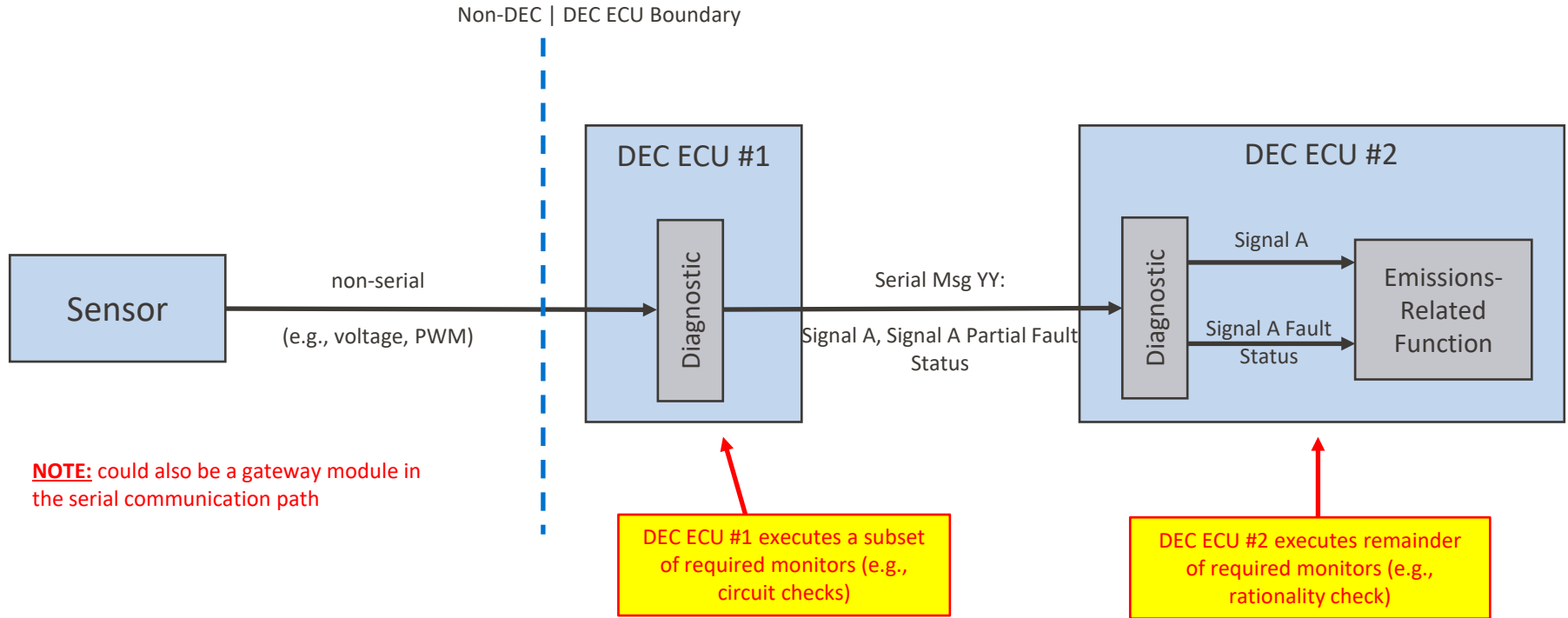

Outlook & next steps

Work in progress:

- Definition of test scenarios
- Definition of use cases

Next steps:

- Define exchange file format
- Collect best practices from existing processes

HRCS Role in the OBD Signal Flow Analysis

- Provide neutral, precompetitive, non-proprietary environment
- Increased bandwidth and shortened response time
- Will produce a common and coordinated approach to this challenge
- Differing perspectives of participants will produce a better final solution
- HRCS will produce, file, maintain, and market needed templates for this effort
- For more details / membership please contact:

Peter Grau

Program Manager

SAE HRCS

Peter.Grau@sae-itc.org

Call for action! – Join HRCS

- Harmonize Industry Challenges with Regulatory Requirements
- Find realistic and cost-effective solutions

Contact Info

Thank You

Matthias Hampel
Concentrio AG
Riesstrasse 12, 80992, Munich, Germany
+49 89 998 29 60 – 80
matthias.hampel@concentrio.io